



ECOSOFT MO-2 reverse osmosis system

**PURPOSE.** Ecosoft MO-2 is an industrial reverse osmosis system for purification of brackish water. Ecosoft RO systems feature simple and effective design for high recovery low energy operation.

**MAIN SPECIFICATIONS:**

Nominal capacity <sup>1</sup>	2.0 m <sup>3</sup> /h
Permeate recovery rate <sup>1</sup>	75%
Electrical requirements	400 V, 50 Hz (3 phase)
Power requirements	4 kW
Membrane elements	Dow Filmtec™ 2 pcs
Crate dimensions (Height x Width x Depth)	2.2x2.1x1.3 m

<sup>1</sup> At 15°C, 2000 ppm feed water, ±10%

Purified water is used in most sectors of industry.

Main applications of Ecosoft RO systems include:

Steam boilers	Semiconductor industry
Agriculture	Heating and cooling circuits
Chemical industry	Pharmaceutical industry
Food industry	Galvanic and electroplating
Textile industry	Utility water treatment
Insulation glazing	Laundry and car wash
Desalination	Drinking water bottling

**ASSETS OF ECOSOFT RO SYSTEMS**

- Energy efficiency with Filmtec™ XLE membranes and Grundfos® CR pump
- Reliable operation thanks to high quality parts and equipment
- Individual project evaluation per request
- CE label for electrical safety compliance
- ISO 9001 certified factory



**MAIN EQUIPMENT.**

DOW Filmtec™ XLE membranes
Grundfos CR pump
Danfoss motorized valves
Honeywell regulating valves
Ecosoft RO controller
Praher and John Guest pipe, fitting, and valves
Sediment pre-filters
3 pressure switches
Float switch
Conductivity probe
Anti-vibration pressure gauges and rotameters
Powder coated steel frame



ECOSOFT MO-2 reverse osmosis system

OPTIONS.

Special purpose DOW Filmtec™ membranes	— For problem water with high nitrate, ammonium, TDS, TOC or other water quality issues
EMEC dosing pump	— For hard water or other water quality issues
Permeate rinse	— Prolongs membrane life and extends runtime before membrane clean (CIP)
Raw water blending	— Corrects purified water analysis and increases total flow rate

DIMENSIONS <sup>1</sup>.

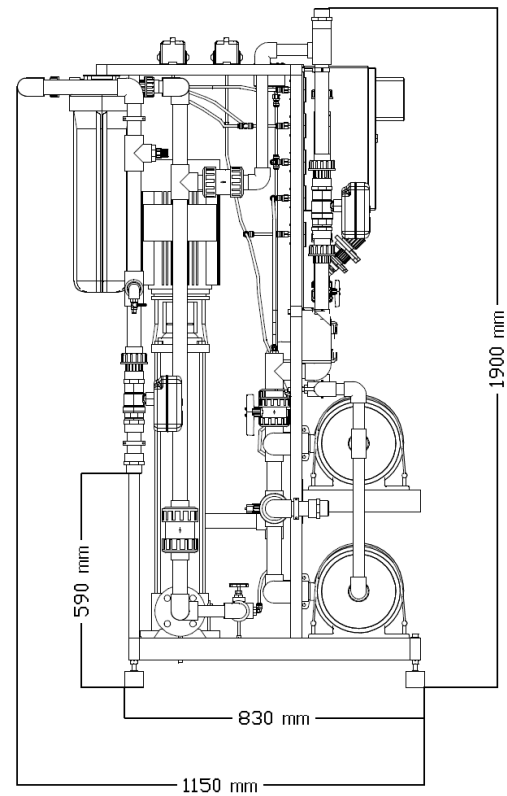
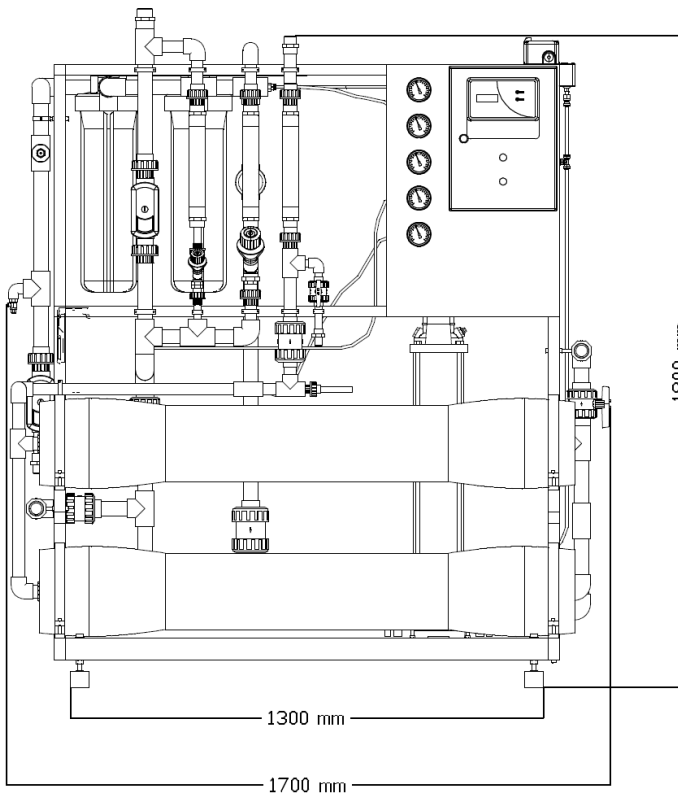

<sup>1</sup> Above dimensions are not binding and may vary within 30 mm



## ECOSOFT MO-2 reverse osmosis system

**EXTENDED SPECIFICATIONS.**

Pump power		4 kW
Inlet pressure of water <sup>1</sup>		2...4 bar
Operating pressure		7...10 bar
Maximum pressure		14 bar
Influent flow rate during service		2,5...4 m <sup>3</sup> /h
Influent flow rate during rinse		8...10 m <sup>3</sup> /h
Connection port sizes:	— feed water	DN32
	— permeate	DN25
	— concentrate	DN32
Clean-In-Place port sizes:	— in (feed)	DN32
	— out (concentrate)	DN32
	— out (permeate)	DN15
Dimensions (Height x Width x Depth)	— product	1.9×1.7×1.2 m
	— crate	2.2×2.1×1.3 m
Weight	— product	400 kg
	— crate	520 kg

<sup>1</sup> stable pressure (±0.5 bar) within specified limits is required for sustainable operation

**FEED WATER REQUIREMENTS.**

1	Total Dissolved Solids	< 3000 mg/L (ppm)
2	Hardness <sup>2</sup>	< 150 mg/L CaCO <sub>3</sub> (ppm CaCO <sub>3</sub> )
3	Iron	< 0.1 mg/L (ppm)
4	Manganese	< 0.05 mg/L (ppm)
5	Hydrogen Sulfide	none
6	Silica <sup>2</sup>	< 20
7	Chlorine	< 0.1 mg/L (ppm)
8	Silt Density Index	< 5 mg/L (ppm)

<sup>2</sup> higher value can be treated with antiscalant